



MICOM AUTODOOR
Automatic Sliding Door Operator
Model: EDM NII Series

(Effective from Lot No. 1206)



Original Instructions

OPERATION MANUAL



130k / 80k

IMPORTANT NOTICE

	<p>Please read these instructions carefully before installing the door operator. We are not responsible for any loss or damage if these precautions are not followed. The device must be installed correctly according to the installation and wiring instructions.</p>
	<p>During maintenance and installation, the power should be turned OFF.</p>
	<p>Please use the correct power supply. Control box accepts 100VAC only. (Do not connect 220-240VAC directly)</p>
	<p>Make sure that the operator is grounded or connected to earth! The coating of the operator is made of an electrically conductive metallic material, which will easily induce electrical conduction! Make sure the ground or earth wire is connected!</p>
	<p>The operator housing is not completely sealed, therefore it should be noted that excessive moisture or a corrosive atmosphere could destroy the electronic components contained within.</p>
	<p>Do not attempt to modify, repair, or alter any parts within the control box. Do not remove screws and bolts from the internal structure of the Control Unit. The failure to comply will result in loss of warranty.</p>
	<p>Installation and maintenance of this product can be performed by MICOM authorized technician or personnel only.</p>
	<p>Before switching ON the power supply, make sure that no objects obstruct the travel of the automatic doors.</p>
	<p>Ensure door travel area is clear before switching power switch ON. Failure to comply may cause incorrect operation.</p>
	<p>Do not switch off power supply whilst door(s) is in motion. Failure to comply could result in death or serious injury.</p>
	<p>Take special care of finger entrapment when used as manual slide door with mains power off. Failure to comply may cause a finger trap hazard.</p>
	<p>Operation speeds should comply to relevant standards</p>
	<p>Do not obstruct door movement. This could result in stalling the door operation, due to our overload protection feature. To re-start, power Off / On is necessary.</p>
	<p>Follow all indicated instructions, as improper installation could cause severe damage.</p>
	<p>Please keep these instructions.</p>

**IMPORTANT SAFETY NOTICE!!!**

When the door starts for the first time, it will automatically perform a series of opening and closing cycles (normally between 3 to 5 times) – Known as ‘teaching’ or ‘self-learning’ mode. Please note these learning cycles are performed at LOW speed.

Keep clear of the entrance and doors. Ensure that no pedestrians pass through the doors during initial learning, installation or maintenance. Keep clear of doors when opening or closing during learning. It is advisable to identify and restrict the area with warning signs.

Contents

No.	Section	Page
1	Identifying Control Box Features and Modes	5
1.1	Main Control Box NII Series	5
1.2	Switching: Operation mode and Initialization	6
2	Requirements	7
3	Executing Self learning cycle (TEACHING)	7
4	Control Box settings 1 (Hardware settings by switches)	8
4,1	Setting for open direction	8
5	Control Box settings 2 (Software settings for internal parameters)	9
5.1	Basic Settings	9
5.1.1	Hold Open time	9
5.1.2	Opening/Closing Speed	9
5.1.3	Opening/Closing Cushion (Low) Speed	9
5.1.4	Opening/Closing Break Force	9
5.1.5	Opening/Closing Force (Torque)	9
5.1.6	Pressing Force	9
5.1.7	Partial Open (Half Open)	10
5.1.8	Teaching Stroke	10
5.1.9	Other Function Use	10
5.2	Applied Settings	11
5.3	LED display – How to operate, read and change settings	12
5.4	Parameter List	14
5.4.1	Basic settings Code table	14
5.4.2	Application Code setting group 1 (d codes) table	15
5.4.3	Application code setting group 2 (P codes) table	17
5.4.4	Error code (E codes)	19
6	Extended functions	20
6.1	Description of signal of OUT board	20
6.2	Description of signals of I/O board	21
6.3	Signal layout on the extension boards	22
6.4	Corresponding table between Board address and DIP switch	22
7	Adjustment of sensor	22
8	Checking Operation	23

1. Identifying Control Box Features and Modes.
1-1 Main Control Box NII Series

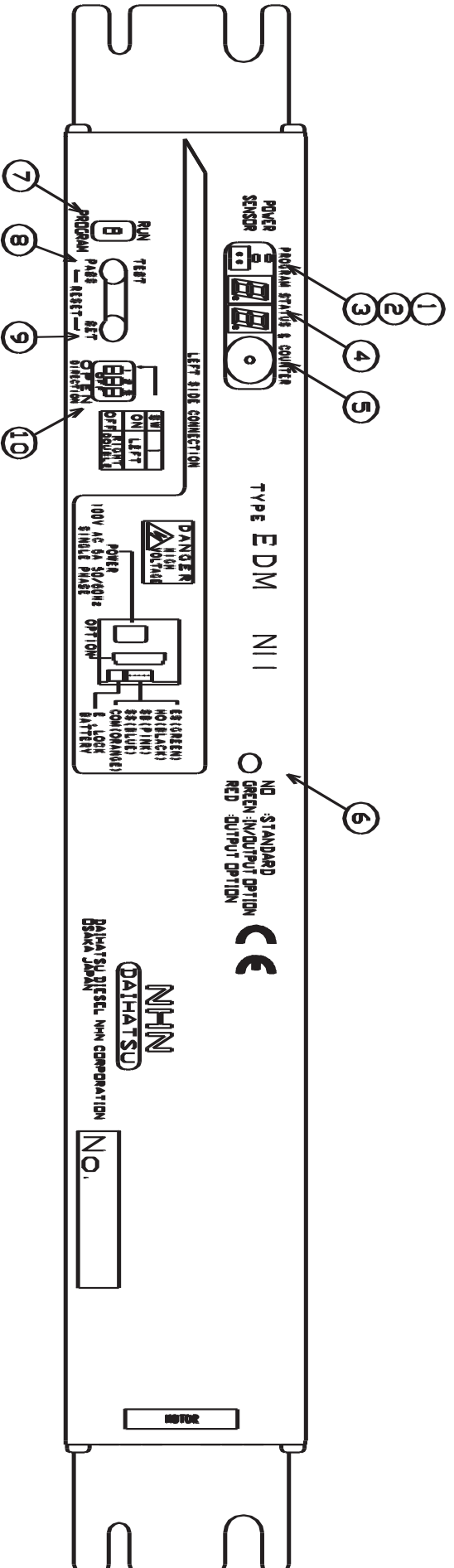

<p>1 Green LED (Light Emitted Diode)</p> <p>1. Power indicator</p> <p>2. When in 'program mode' – Green LED flashes</p>	<p>6</p>	<p>LED Indicator of Extension Board (If included)</p> <p>Green: Input-Output board / Red: Output board</p>
<p>2 Red LED (Light Emitted Diode)</p> <p>1. Sensor indicator / activation</p> <p>2. Program setting. Application ON/OFF indicator</p>	<p>7</p>	<p>Run / Program Switch</p> <p>Change into Program mode from Run Mode.</p> <p>* Additional operation required</p>
<p>3 2P connector - Factory test use only.</p>	<p>8</p>	<p>Test Button / Pass Button - When switched to:</p> <p>Run mode: Activation Signal for Test open cycle</p> <p>Program mode: Changes current setting code or value</p>
<p>4 LED DISPLAY (LED 1 & 2) – When switched to:</p> <p>Run mode: Displays Cycle Counter (Stepped in 10,000 Cycles)</p> <p>Program mode: Displays Setting code and Value</p> <p>* During start up: Displays optional extension board number, if included</p> <p>* In case of Error: Displays Error code</p>	<p>9</p>	<p>SET button – When switched to:</p> <p>Program mode: Change or accept setting value</p> <p>Run mode: Press and hold for 5 sec. Full Cycle counter will appear</p>
<p>5 Buzzer</p> <p>If Buzzer setting is ON will beep to indicate: Error, Emergency open or close mode, Battery operation mode. (ref. d0 setting code)</p>	<p>10</p>	<p>DIP switch</p> <p>Switch 1: Setting for open direction (Do not adjust Switch 2 & 3)</p> <p>Switch 2&3: Must be in OFF position (Factory test use only)</p>

1-2 Switching: Operation mode and Initialization.

- Run mode

In this mode the door moves normally.
- Check mode

In this mode you can confirm the current settings of parameter. However you cannot change settings.
- Program mode

In this mode you can confirm and change current settings and values. Reset to factory default settings is also available.
- Reset Operation (Factory Default Reset)

If you change some settings by mistake and the door does not move correctly, it is easy to recover to factory default settings by reset operation.

If you execute reset operation, default factory settings will be reloaded, except for special setting code "C", which is included within the basic code group.

At the same time, door stroke data (teaching) is cleared from the memory. Therefore it will be necessary for the control to relearn the door stroke. A self learning (teaching) operation will automatically commence after the run mode is selected again. Re-adjustment of settings may be necessary after reset operation.

If the door weight or door stroke are changed, reset is also required.
- How to execute Reset Operation (Factory Default Reset).

Holding both PASS and SET buttons while in Program mode. A beep sound will indicate reset is successful. (Hold for approx 5 seconds)

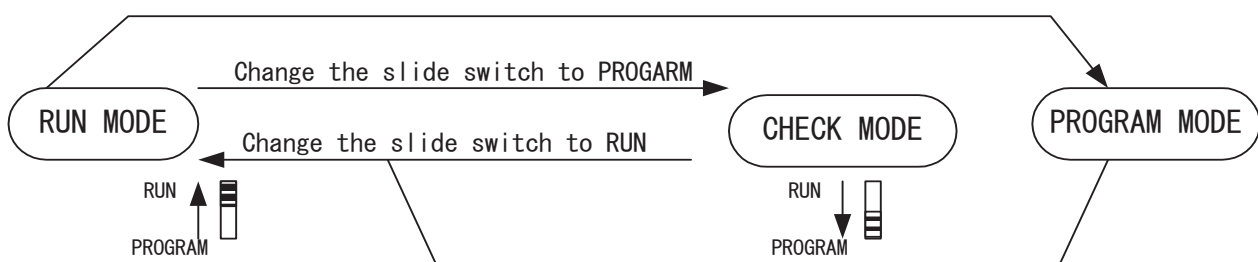

2. Installation Requirements – ENSURE:

- All components have been installed correctly in accordance with the installation manual and all wiring has been connected referring to EDM NII Series wiring drawings. (except main cover and activator on the main cover)
- The door should be easily moved open and closed by hand without abnormal sounds.
- Confirm that wires and cables do not touch moving components such as belt or hanger roller assembly.
- Run / Program mode selecting switch should be set in 'Run' position to execute the teaching operation.

3. Executing Self learning cycle (TEACHING)

- Self learning cycle is executed after installation by turning the mains power switch ON for the first time. The door will close (*1) to the full closed position, then open automatically (*2) at slow speed. When the door has reached to the full open position, the first stage of the teaching cycle is complete and the door will start to close at normal speed.
- Activate the sensor and check the door will open smoothly. Here, the braking position is located at the center of doorway is automatically calculated. After a few cycles, the operator will optimize the braking point taking into consideration operating speed, braking force and door weight.
- Teaching data such as the door stroke and braking position will be stored within the control unit, even if the mains power is OFF.
- Once the mains power is turned ON, the stored data will be reloaded when the door reaches the fully closed or open end position.
- Motor torque value during teaching mode will be the same as factory default values. Or if re-teaching, will be the same as basic setting code values held within the memory. For max torque when teaching switch application code 'dL' OFF.

(*1) If the door does not close, check Red LED (sensor indicator) is ON. If Red LED is ON, this means there is an activation signal being received. Once reaching the full open position, after the sensor signal is off and the hold open time is complete, the door will close and return to full closed position.

(*2) If teaching stroke setting (Basic Setting Code 'b') is changed from factory default setting. The teaching function will not be automatic. It is required to be activated by a sensor or test button, after door has reached full closed position. The door will open at programmed teaching speed. On Activation of sensor before fully closed, the door will re-open at slow speed.

4. Control Box settings 1 (Hardware settings by switches)

4-1 Setting for open direction

Door open direction is set by a DIP Switch on the Control Box (CB).

DIP Switch 1 is for determination of open direction. As shown.

DIP Switch 2 and 3 shall be in OFF position.

SW	1	2	3
ON(Up)	LEFT		
OFF(Down)	RIGHT DOUBLE	Shall be in off position	

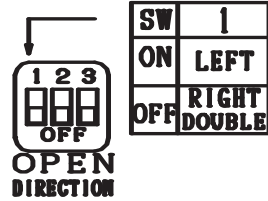

*To confirm change of opening direction – Mains Power OFF / ON is necessary.

5. Control Box settings 2 (Software settings for internal parameters)

For standard doors it is possible to operate with default settings. A standard door is a single leaf door that weights approx 45kg to 90kg. However attention must be paid to the DIP Switch setting for open direction.

Heavier door(s) that exceed standard door limits in weight and size will require adjustment of parameters in order to optimize door operation.

5-1 Basic Settings

According to door operation requirements, door parameters can be changed as follows:

5-1-1 Hold Open time Basic setting code (LED1) '0'

Hold open time is adjusted in 16 steps from '0 to F', by basic setting code '0'.

Value	0	1	2	3	4	5	6	7	8	9	A	b	C	d	E	F
time(sec)	0	1	2	3	4	5	6	7	8	9	10	20	30	40	50	60

5-1-2 Opening/Closing Speed Basic setting code (LED1) '1&5'

Opening speed is adjusted in 16 steps from '0 to F' by basic setting code '1'.

Closing speed is adjusted in 16 steps from '0 to F' by basic setting code '5'.

5-1-3 Opening/Closing Cushion (Low) Speed Basic setting code (LED1) '2&6'

Opening cushion (low) speed is adjusted in 16 steps from '0 to F' by basic setting code '2'.

Closing cushion (low) speed is adjusted in 16 steps from '0 to F' by basic setting code '6'.

5-1-4 Opening/Closing Break Force Basic setting code (LED1) '3&7'

Opening break force is adjusted in 10 steps from '0 to 9' by basic setting code '3'.

Closing break force is adjusted in 10 steps from '0 to 9' by basic setting code '7'.

*As default break force is set for light weight doors and/or single leaf door, check and confirm that the break force is correct for your door(s).

5-1-5 Opening/Closing Force (Torque) Basic setting code (LED1) '4&8'

Opening force is adjusted in 10 steps from '0 to 9' by basic setting code '4'.

Closing force is adjusted in 10 steps from '0 to 9' by basic setting code '8'.

*If using narrow and/or light weight door(s). To prevent jumping when the doors start to move, set Open/Close Force (torque) value lower. Normal doors require setting minimum '3' and above.

5-1-6 Pressing Force Basic setting code (LED1) '9'

Pressing force is adjusted in 5 steps from '0 to 4' by basic setting code '9'.

If you select 0, pressing function is disabled. (No pressing force)

5-1-7 Partial Open (Half Open)

Basic setting code (LED1) 'A'

Partial open is defined by a percentage of the full open width as shown in the chart below.

Partial open operation is related to setting 'd/7' of the applied setting group 1(d codes).

Value	0	1	2	3	4	5	6	7	8	9
Width (%)	12.5	25	37.5	50	62.5	75	87.5	93	95	98
								Fix mode only		

If you set 'd/7' OFF (AUTO) (Default Setting), upon the door being held open by heavy traffic, the partial open position will change to full open position automatically.

If you set 'd/7' ON (FIX), the partial open setting will not to change to full open.

If you select partial open width to setting 7, 8 or 9, automatic full open function is disabled, to prevent a finger trap hazard.

5-1-8 Teaching Stroke

Basic setting code (LED1) 'b'

Changing Teaching Stroke from default setting: Please note there is no need to change from the default factory setting.

It is possible to set the teaching length value from 1 to 9. This corresponds to the length of travel, which will be at full speed.

If you set at '1' or higher, the door will open at normal speed, performing the teaching stroke. Note that the teaching stroke MUST not exceed more than 70% of total door stroke.

If you set at '0' (default), the door will move a low speed until the teaching stroke is complete. (Generally the teaching stroke is only required once during set up or after adjustment).

Value	0	1	2	3	4	5	6	7	8	9
Teaching Stroke(cm)	0 ALL SLOW	30	60	90	120	150	180	210	300	400

5-1-9 Special Function Use

Basic setting code (LED1) 'C'

C-0 = ES - Emergency Stop (Factory Default).

In case an emergency signal is received, the control will immediately stop the door in any position. This can also be used and applied to breakout mechanisms. Upon turning off ES signal, the door will return to closed position.

C-1 = H1 - Heavy Door / Resistance.

H1 setting allows the user to utilize EDM NII for cold room applications and/or heavy doors. This is particularly useful in case of cold room doors. H1 will delay registering an E1/E2 Error for 2.5sec after activation. This gives time to for the movement of heavy doors to begin. Unlike lighter doors whereby E1/E2 will be registered if there is no movement 0.5sec from activation.

C-3 = EMS - Battery Back Up.

EMS Battery back-up allows normal operation (open/close) for as long as the battery has charge. Open and close speed are steady, however speed may be affected.

C-7 = PS - Panic Signal.

Panic Signal once activated, overrides any another signal and will reverse the door to full open from any position. Panic Signal is commonly used in case of Fire Alarm input or together with our battery system.

C-8 = RS - Ratchet Function.

Ratchet Function (Flip-Flop) allows the user to operate the door by pressing an activation button once to open the door. The door will not close and remain in the hold open positions for an infinite amount of time. The user can close the door by pressing the activation button again, and then the door will return to the closed position.

C-9 = AS - Side Screen Safety Function.

Side Screen safety input allows the use of additional sensors to protect the area in front of the door/s leading edge when opening. For example, following activation of the main sensor (SS), the door will begin to open. Upon a pedestrian standing in front of the leading edge, a sensor mounted above this area, called side screen safety (AS) will be activated. SS and AS signals are now both ON, the door will creep at low speed until the AS input goes OFF. Once AS is OFF, the door will resume normal opening speed.

C-A = HS – Half Open Function.

HS is a special half open function used as a standalone half open signal, for use in factory locations for example. HS is used when you need to combine Full Open and Half Open functions. In case a large cargo is to pass through a large entrance, the doors are operated by SS signal. This gives full open. In case pedestrian are to pass through the same entrance, use of a push button connected to HS can be used and the door will open partially, in order to allow pedestrians through without opening fully. Standard Half open HO signal is independent of HS signal.

5-2 Applied Settings

Changing applied setting might be helpful for some special operation applications

To use applied settings, NII-G (I/O Board – Input/ Output) or NII-R (Output Board) type control box may be required in some cases. Please enquiry for more details.

5-3 LED display – How to operate, read and change settings

RUN Mode

Normal operation

Open Counter



- The LED indicator shows number of open cycles (door open counter) from 10 thousand to 990 thousand, except when the door is at full opened position.
- This example indicates the door has opened more than 230 Thousand times.
- A decimal point appears continuously when the door counter exceeds one million.
- The LED Display will turn OFF 2 minutes after the door is closed.
- The total number of door cycles can be read by depressing SET button and holding. LED display will indicate "oP" followed by number of open cycles.

Decimal point.

Depress and holding the SET button.

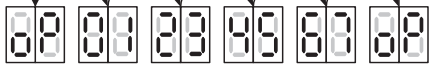

This above example shows open counter value at 1,234,567 cycles

Error Indication

Indication order

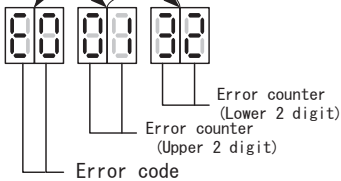

Error counter (Lower 2 digit)
Error counter (Upper 2 digit)
Error code

Error Counter Indicator

- Indicator shows the error code and it's counter.
- The value of each error is from 0000 to 9999. (Maximum value is 9999)

This above example shows when E0 error is happening and total counter of this E0 error is 132 times.

Error (Indicates Error which has just happened)

Check mode, Program mode

Basic setting group

0 Open Time

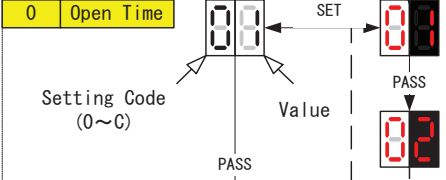

Setting Code (0~C) Value

1 Open High Speed

C Special Setting

Note: Only during program mode, set button is active.

Applied setting group 1 (on/off setting)

d0 Buzzer

Red LED (Value)

d1 d2 d3 Electro

d0-dL OFF&ON

*Red LED is same as Sensor Indicator

Each function will be active when LED is ON.

Application Code group 2 (Japanese Only - Except PE)

P1 Sensitivity

Red LED

Setting Code Value

Red LED will glow if changed from default setting

Error history (counter)

E0 Teaching Error

E9 Internal Reset

Error Counter

Error Code

Indicator shows how many times errors have occurred (error counter) after Error code. Above example shows E0 (teaching) Error has occurred 19 times.

Return to basic settings

IMPORTANT NOTES – MOTOR PROTECTION: NII Control Box will now find the error and stop the motor by itself to prevent overheating of the motor by overload.

Previous to this NII Control Box version, if Error E1 (Opening Safety) or E2 (Closing Safety) happened continuously, the control box would register an E0 Error. Should E1 or E2 Error continue to happen and not be resolved, an E0 Error would register 5 times in a row, at which point the Control Box would stop the motor. An E0 Error would be shown on the LED display and the door would be in a failsafe stopped position.

With this New Control Box version, it will now stop the motor when an E1 or E2 Error happens 5 times in a row. This is for added protect of the motor. Please note an E0 Error will no longer be applicable to this type of overload situation.

IMPORTANT - To return back to normal operation:

1. To recycle the doors and reset Error protection (failsafe mode) switch mains power Off/On.
2. Please look to solve the cause of error. E1 and E2 Errors are mainly resolved by reducing the physical resistance on the door. Note the door must run freely and easily.

Doors should be easy to push open by hand. Travel must be smooth and without noise.

Previous to this NII Control Box version, incase teaching distance is less than 150mm, an E0 Error would be registered automatically, this would be added to other continuous E0 Errors and the motor would continue to operate.

With this New Control Box version at the first E0 error, the door would assume in a failsafe stopped position. Just in case rollers are not sitting on the rail correctly.

This motor protection features is always activated.

When the motor stops, green and red LED blinks at the same time

Buzzer for error notice can be used when switching Application Code setting 'd0' on.

5-4 Parameter List

5-4-1 Basic settings Code table

Code	Parameter names	LED Indicator		Setting Range		
		LED1 Code	LED2 Value	Min	max	
0	Hold Open Time	0	1	0	F*	
1	Open High Speed	1	9	0	F*	
2	Open Low Speed	2	5	0	F*	
3	Open Break Force	3	4	0	9	
4	Open Force	4	4	0	9	
5	Close High Speed	5	5	0	F*	
6	Close Low Speed	6	4	0	F*	
7	Close Break Force	7	4	0	9	
8	Close Force	8	4	0	9	
9	Pressing Force	9	1	0	4	
A	Partial open width	A	3	0	9	
B	Teaching stroke	b	0	0	9	
C	Special settings	C	0	0: ES Standard 1: H1 (Cold Room) 3: EMS 7: PS 8: RS 9: AS A: HS		Select only to the number shown for input function.

Default
Setting

*Note; The value follow in sequence from 0 to F. (0,1,2,3,4,5,6,7,8,9,A,B,C,D,E,F)

5-4-2 Application Code setting group 1 (d codes) table

This group contains setting parameters, which are either ON or OFF.

NEW – Function Added

Memorizing Application Code Settings – Application Code Setting can be retained after any control box reset.

(Previously, application code settings were also returned to default settings after a control box reset.)

See Application Code 'dP' to retain Applications Code Settings.

CODE INDICATION		Parameter name	DESCRIPTION	LED 4 (RED)	
LED 1	LED 2			ON	OFF*
d	0	BUZZER	Set ON when you need buzzer sound, in case of error, battery operation or PS operation.	ON	OFF
d	1	CLOSE BRAKING POSITION	Set ON (150mm) if you need a wider cushion / low speed travel range before fully closed.	150mm	70mm
d	2*	18 / 30 MODE (AUTO)	Setting Automatically when the motor for EDM30NII is connected.	30	18
d	3	ELECTROMAGNETIC LOCK	Setting ON Automatically if an Electromagnetic Lock is detected. Set to OFF when the Electromagnetic Lock is NOT connected.	YES	NO
d	4	BATTERY SYSTEM (Emergency system)	Set on with Battery Close system (BC) or Set on when you need to CLOSE by Panic Signal (PS).	BC	BO
d	5	OPEN PRESSING	Set ON if you do not need pressing force at full open.	NO	YES
d	6*	CLOSE PRESSING (Vibration detected)	Set ON if the motor generates vibration at closed position. Closing press will be cut off only when vibration detected. Set OFF. Always closing press at full close.	YES & NO	YES
d	7	HALF OPEN mode (Partial open)	Set ON if you do NOT wish partial open to go to full open automatically.	FIX	AUTO
d	8	RS – Hold Open Ratchet Switch	New Function - If SB is ON during closing, the door will re-open and remain open in Ratchet (RS). To close, switch (RS) must be activated again. Set ON to Hold Open after SB.	ON	OFF
d	9	SB FUNCTION ON CLOSE END	Set on if you need to open by SB signal when the door fully closed.	YES	NO
d	A	SELF CLOSING DEVICE (Mechanical open device)	Set ON if mechanical self closing device is fitted (Japan Only)	YES	NO

d	B	SAFETY FUNCTION (When obstruction)	Set OFF in case of an obstacle during the closing travel, the door stops and RETURNS to full open. Set ON if you do not want the door to RETURN. Just STOP	STOP	RETURN
d	C	RS FUNCTION DURING OPENING (Special Ratchet Function)	Set ON for RS signal to release door at hold open. RS is not accepted during the open travel for safety reason. Set OFF (yes) if you allow RS signal during opening travel.	YES	NO
d	D	INTER-LOCK	Dual door connection and control (Japan Only)	YES	NO
d	E	Hold Open (Push Button)	Activation by Push Button only. If SB is ON during closing, the door will re-open. The door will hold open and only close with a Push Button (SS & G) activation. (Door will not close after set open time).	YES	NO
d	F	AS FUNCTION (Side Screen Safety)	DOOR: AS signal only accepted during opening cycle On AS activation, door moves slowly. FIX: AS signal only accepted in Door Closed or Full open position. Door will not move. While door is moving AS signal ignored For AS signal – Setting C-9 must be selected.	DOOR	FIX
d	H	DOOR PRESS WHEN ES	Set OFF in case breakout / panic door is in use with ES signal. (Stop after break out) Set ON if door press function is required with ES signal. (continue to full open after break out)	ON	OFF
d	J	LOW SPEED WHEN POWER ON	Set ON if the speed during the teaching cycle is too fast.	PROGRAMMED	MAX
d	L	TORQUE WHEN POWER ON	Increase the programmed torque power or Set ON if the door force during the teaching cycle is not strong enough.	PROGRAMMED	MAX
d	P	Retain Application Code Settings after Reset to Default Values	Set ON to retain Application Code settings after manual reset to default values. Note: d3 is reset to 'NO'.	ON	OFF

Warning: Adjustment of parameter should only be carried out an authorized representative. Parameters should not be changed unless the person performing the change understands the operation of the product. Otherwise the door may not operate correctly after adjustment.

All parameter are OFF (factory default settings). Only dL is now ON from Lot 1206.

5-4-3 Application code setting group 2 (P codes) table

Note: Setting P1 to Pd & PF are for Japanese domestic use and not required to be employed out side of Japan. The full range of P codes are available, however only PE code is only NECESSARY to be utilized when required.

We recommend NOT changing these parameters unless advised to do so. They are for special use, except in the case of PE code, which changes Normal Open Contacts to Normal Close Contacts.

CODE INDICATION		Description
CODE	SETTING	
P1	00~60	Error detection threshold during high speed opening cycle
P2	00~60	Error detection threshold during low speed opening cycle
P3	00~50	Low speed travel range during opening cycle.
P4	0.3~2.5	Start opening error detection time
P5	00~50	Error detection threshold during high speed closing cycle
P6	00~10	Error detection threshold during low speed closing cycle
P7	00~50	Low speed travel range during closing cycle.
P8	0.3~2.5	Start closing error detection time
Pb	0.0~1.0	Door opening delay time
PC	02~30	Activation signal delay time
Pd	00~50	Error detection threshold by obstacle size during closing cycle
PE	00~0F	NO, NC SELECTION (SEE CHART BELOW)
PF	00~09	Before closing warning signal time
PH	00-05	Breaking & Stop Movement – Time before Low Speed after breaking
PJ	02-04	Interval of Door Speed Checking (02=0.2sec / 04=0.4sec)
		Setting PH-00 & PJ-02 – Door movement from breaking to low speed is very smooth Setting PH-05 & PJ-04 - Door movement from breaking to low speed is very sudden. (Door Stop – Low Speed)
PL	00--02	Open Pressing Power

If you change from default setting the parameter of P code, the RED LED is turned to ON.

PE Code: NO or NC SELECTION CHART (Blank columns - NO contact)

CODE	SETTING	AS	SB	PS	ES
PE	00				
PE	01				NC
PE	02			NC	
PE	03			NC	NC
PE	04		NC		
PE	05		NC		NC
PE	06		NC	NC	
PE	07		NC	NC	NC

CODE	SETTING	AS	SB	PS	ES
PE	08	NC			
PE	09	NC			NC
PE	0A	NC		NC	
PE	0b	NC		NC	NC
PE	0C	NC	NC		
PE	0D	NC	NC		NC
PE	0E	NC	NC	NC	
PE	0F	NC	NC	NC	NC

5-4-4 Error code (E codes)

Code indication	Error Name (Buzzer sound pattern)	Troubleshoot (Possible Causes, Description, Remedy)
E0	Failed teaching (— — — long sound only and no short sound)	Door travel distance during teaching cycle is too short. (less than 150mm) Door speed and/or braking force do not match the door weight (Increase braking force or reduce operating speed) Obstructed during teaching cycle. Teaching stroke setting (Basic code setting “b”) is wrong. Wire connection problem or hardware problem. (Change the controller and/or motor) Note: Operational stop after x1 times E0 error occurs. During operational stop, both GREEN & RED LED flash. (With Buzzer sound – if switched ON). To recover, confirm the door is not locked. Switch mains power OFF and ON. Re-teach will be performed.
E1	Open error (·—·—·— 1 short sound between long sounds)	Obstruction during the opening cycle. Door is physically locked.
E2	Close error (······— 2 short sound between long sounds)	Obstruction during the closing cycle.
E3	INTER-LOCK (·····— 3)	Inter Lock system failure
E4	LOOSE BELT (·····— 4)	Obstruction during teaching cycle just after Power on. Door is physically locked. Loose belt.
E5	BROKEN BELT (·····— 5)	Broken belt
E6	Electro Magnetic Lock (·····— 6)	Wrong setting on control box – Check: Lock or no Lock Lock pin dose not move properly Check wiring of lock cables
E7	No. of Times Battery and emergency operation (·····— 7)	Not error - Battery operation or PS signal is activated.
E8	Times of power on	Not error - Number of power on
E9	Internal reset times	Not error - Number of internal software reset (Usually almost equal to values in E8)
EA	Internal interference	Error from inside the control box such as interference from heavy noise.

Code indication	Error Name (Buzzer sound pattern)	Troubleshoot (Possible Causes, Description, Remedy)
Eb	Wrong setting of DIP switch	DIP switch 3 is in wrong position. (No counter of error history)
EC	Over load	Door resistance is increased from initial installation. - Confirm and clear / reduce the door resistance. (should be easy to push by hand) In case this error occurs, the hold open timer changes internally to 30 seconds. Display will only show this error only when the EC error is currently occurring. (No counter of Error history)

Error counter will appear after error codes displayed. See section 5-3.

6. Extended functions

Optional functions are available with NII-R type controller which includes an extension board named OUT board, or with NII-G type controller which includes another extension board named I/O board.

Each board has a unique board address setting (by DIP switch), which means you can select each signal function.

6-1 Description of signal of OUT board

Board address	Signal name	symbol (Common side)	Description
0 Default	Opening	OPN (CO)	Output during opening motion
	Closing	CLS (CC)	Output during closing motion
	Stop	STP (CS)	Output if door stopped (excluding full open/closing)
	Half-OPening	HOP (CH)	Output during half-opening motion
1	WArning	WA (CW)	Output before starting to close
	ERRor	ERR (CER)	Output when an error occurs (until restored)
	Open End	OE (COE)	Output at a fully open condition (same as OA on the I/O board)
	Close End	CE (CCE)	Output at a fully closed condition (same as CA on the I/O board)
2	Safty Beam	SBO (CSB)	Output while photocell is being detected
	UnLock	UL (CUL)	Output showing that an electric lock is unlocked

6-2 Description of signals of I/O board			
Board Address	Signal name	Symbol	Description
4	Opening brake	LOB	Limit switch to designate the position to retard opening
	Closing brake	LCB	Limit switch to designate the position to retard closing
	Half-opening brake	LHO	Limit switch to designate the position to retard half-opening
	Closing stop	LCS	Limit switch to designate the position to stop closing
	LS mode	SPC	Enable Limit switch mode operation
	Emergency Open	EO	Open for 15 seconds at a low speed
	Open A (Output)	OA	Make relay contact at full open position. OE SIGNAL RELAY A
	Open B (Output)	OB	Break relay contact at full open position. OE SIGNAL RELAY B
	Close A (Output)	CA	Make relay contact at full closed position. CE SIGNAL RELAY B
	Close B (Output)	CB	Break relay contact at full closed position. CE SIGNAL RELAY B
5	Push Button for Opening	PBO	Open and hold open until the other push button is depressed
	Push Button for Closing.	PBC	Close
	Push Button for Stop.	PBS	Stop and stay until the other push button is depressed.
	Push Button for Half opening.	PBH	Partial open and stay at the designated position.
	InterLock	IL	Enable opening in the interlock mode.
	Priority	PR	Designate the priority door in the interlock mode.
	Open A (Output)	OA	Make relay contact at full open position. OE SIGNAL RELAY A
	Open B (Output)	OB	Break relay contact at full open position. OE SIGNAL RELAY B
	Close A (Output)	CA	Make relay contact at full closed position. CE SIGNAL RELAY B
	Close B (Output)	CB	Break relay contact at full closed position. CE SIGNAL RELAY B
6	Panic Switch	PS	Emergency operation / Panic Open or Close
	Ratchet Switch	RS	Hold-open/Close switchable
	Half-open Ratchet switch	HRS	Partial open and hold open until next signal.
	Outer Sensor Enable	OSE	Enable the outer sensor in the security mode.
	Ratchet Switch 1	RS1	Open/Close/Stop in the middle of opening switchable
	Open A (Output)	OA	Make relay contact at full open position. OE SIGNAL RELAY A
	Open B (Output)	OB	Break relay contact at full open position. OE SIGNAL RELAY B
	Close A (Output)	CA	Make relay contact at full closed position. CE SIGNAL RELAY B
	Close B (Output)	CB	Break relay contact at full closed position. CE SIGNAL RELAY B
7 (Default)	Panic Switch	PS	Emergency operation / Panic Open or Close
	Ratchet Switch	RS	Partial open and hold open until next activation signal.
	Half-open Switch	HS	Partial open
	Emergency stop Switch	ES	Emergency Stop
	Anzen Switch	AS	Side Safety Screen
	Ratchet Switch 1	RS1	Open/Close/Stop in the middle of opening switchable
	Open A (Output)	OA	Make relay contact at full open position. OE SIGNAL RELAY A