



MB24 MBE24

ARTICULATED ARM

with integrated control unit
personalised release key

up to 2.5 m

PRODUCT BEING PHASED OUT



CONTROL UNITS:

- MBE24** ——— CP.MBY24
- MB24** ——— BRAINY24^{PLUS}
BRAINY24



24 Vdc | intensive use

- 24 Vdc self-locking electromechanical operator for intensive use equipped with strong, articulated and anti-shearing arm
- Suitable for gates installed on large posts
- Tempered steel mechanical features to guarantee sturdiness and solidity
- Operation guaranteed even in the event of a power supply failure through batteries
- Amperometric sensor obstacle detection system to prevent crushing
- Equipped with open and close limit switches
- Option of adjustable wire unlock device that allows opening from the outside in the event of a power supply failure

Arm not included

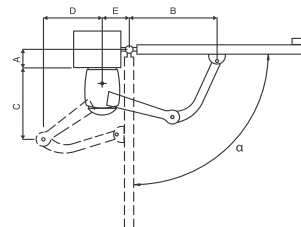
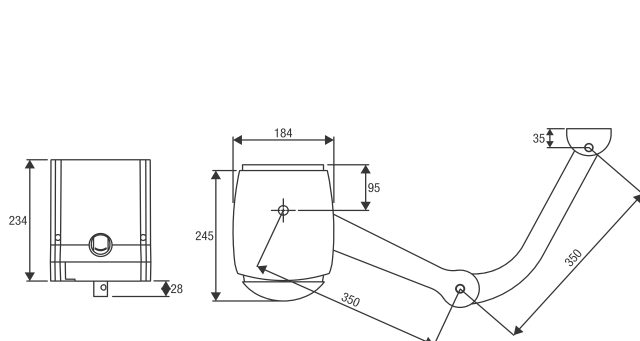

A (mm)	B (mm)	C (mm)	D (mm)	E (mm)	α
0	470	350	243	140	90°
50	470	339	255	140	90°
100	470	331	262	140	90°
150	470	328	264	140	90°
185	470	356	237	160	90°
200	440	410	160	200	90°
0	420	244	318	200	110°
100	420	262	310	200	105°

COMPLETE KITS						
KMB24	MOTOR 1 1x MBE24	MOTOR 2 1x MB24	ARMS 2x BA	PHOTOCELLS 1x PUPILLA.T	FLASHING LIGHT 1x LAMPY	TRANSMITTER 1x TO.GO2VA



BA
Single arm.



BS
Sliding arm.



MB.CP2
Set of counter plates for two operators, suitable for the installation on columns made of stones.



MB.SE
Externally fitted anti-intrusion cable unlock device which allows the gate to be unlocked from outside.



DU.V96
12 Vac/dc vertical electric lock, supplied with counterplate. Permits internal/external release.



DU.V90
12 Vac/dc horizontal electric lock, supplied with counterplate. Permits internal/external release.



DU.9990
Covering plate for DU.V90.

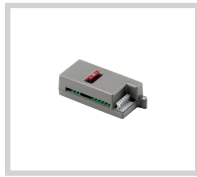

CBY.24V
Battery charger card. The CBY.24V card allows charging two different types of nickel metalhydrate and lead batteries.



DA.BT2
2.1 Ah 12 Vdc Battery.
DA.BT6
7Ah 12 Vdc Battery.



XLB.CB
Battery box fitted with universal bracket and cables. IP54.



DA.LB
Galvanized column for outdoor installation of LB box.

AUTOMATISMI BENINCA SpA • Via del Capitello, 45 • 36066 Sandrigo (VI) ITALY • T +39 0444 751030 • sales@beninca.com

TECHNICAL DATA	MB24	MBE24
Power supply	---	230 Vac (50-60Hz)
Motor supply	24 Vdc	24 Vdc
Max absorbed current	6.2 A	0.76 A
Torque	180 Nm	180 Nm
Opening time	10"	10"
Duty cycle	intensive use	intensive use
Protection level	IP44	IP44
Built-in control unit	NO	YES
Operating temperature	-20°C /+50°C	-20°C /+50°C
Leaf max dimension	2.5 m	2.5 m
Weight	8.2 kg	10.7 kg
Items no. per pallet	39	39
Kit weight	25.4 kg	25.4 kg
Kits no. per pallet	12	12